

Code: **AWO534** v.1.1 / III

EN

Name: **NVR enclosure/Monitor/RACK 10", 19"/vertical black**

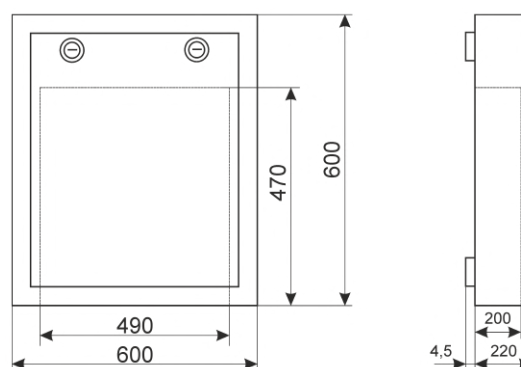

DESTINATION

AWO534 enclosure is dedicated to CCTV systems. Its universal design makes it suitable for simple CCTV installations as well as more complex and demanding ones. Due to vertical installation and low depth, they are ideal for places where deeper enclosures or cabinets RACK 19" type cannot be installed.

Enclosure can accommodate devices such as:

- monitor – monitor mounting standard: VESA 50x50 / VESA 75x75 / VESA 100x100
- switch – standard 19" rack / with special mounting brackets
- DVR – 19" rack standard / using tightening straps (ZPR – additional equipment)
- enclosed power supplies with battery backup: 52VDC-PWB / 54VDC-PSB + DCDC 12 V DC converters
- patch panel – 19" RACK standard
- power strip – standard 10"/ 19"
- The ARAW45 fan

TECHNICAL DATA:

Dimensions:	600 x 600 x 220 [mm, +/-2] distance from surface: 4.5 mm
Dimensions of recorder space:	490 x 470 x 200 [mm, +/-2] Straps for mounting recorder - additional equipment - ZPR
Profile RACK 19:	1U /2U /3U / vertical/horizontal
Dimensions of battery space :	4 x 7Ah / 2 x 17Ah
Closing:	lock (2xRAZ25, with repeatable code) lock assembly possible with various code RAZ534
Material:	cold-rolled steel SPCC, 1.2mm, 1.5mm, black, metallic, protection anticorrosion
Destination:	indoor
Protection grade EN60529:	IP 20
Weight:	19.4 / 22.2 [kg]
Notes:	Monitor mounting standard: VESA 50x50 / VESA 75x75 / VESA 100x100
Warranty:	2 years
Declaration:	CE

Enclosure is equipped with:

- adjustable 10" / 19" RACK mount - 1U
- RACK brackets: 1U - 1 pc, 2U - 2 pcs, 3U - 1 pc
- mounting plate in door - holes for switches and straps

COMPONENTS OF ENCLOSURE:

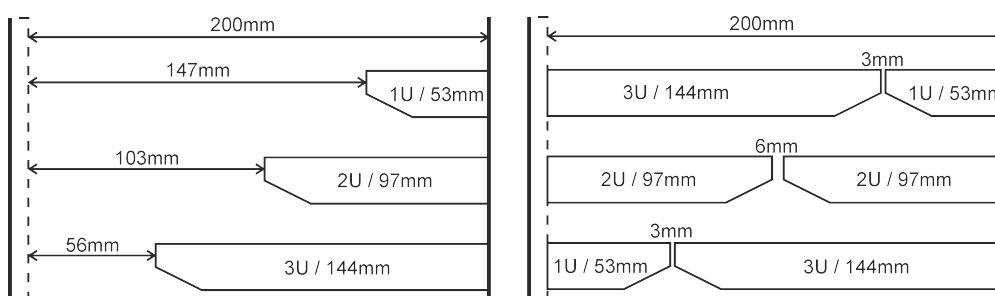
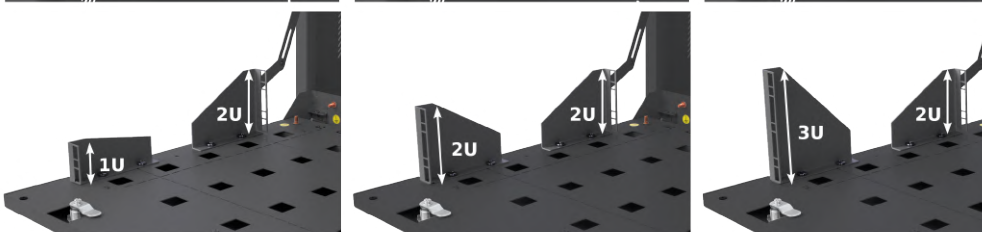
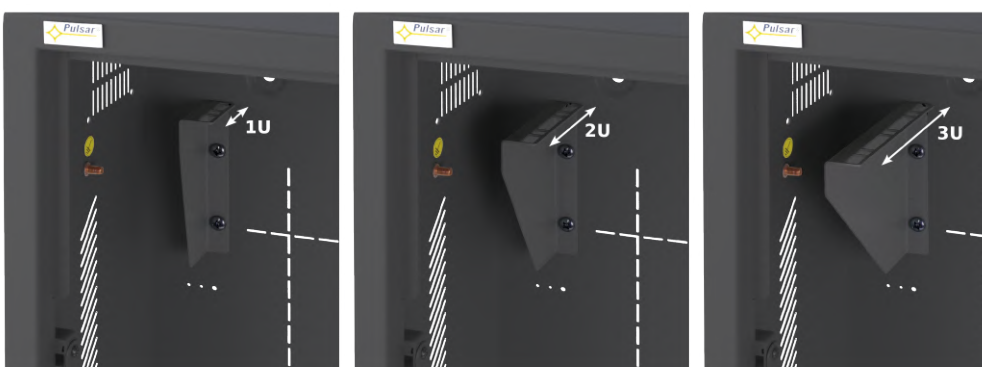

Distances inside enclosure after mounting 19" RACK profiles, 200mm distance: hinged front door - bottom of the enclosure.

